



## 1/198 Gipps Road Gwynneville NSW

A brilliant commercial opportunity with this ground floor premises, occupied by an established business located in bustling, trendy Gwynneville shopping strip.

Features Include:

- \* Great investment opportunity
- \* Long term, 3 year lease with future options ready to be signed
- \* Area 54 sqm
- \* Private off-street undercover parking
- \* High traffic flow

**Building Size** : 54 sqm

**View** : <https://www.jacksonresidential.com.au/6046881>



**Mark Jackson**  
02 4226 3000

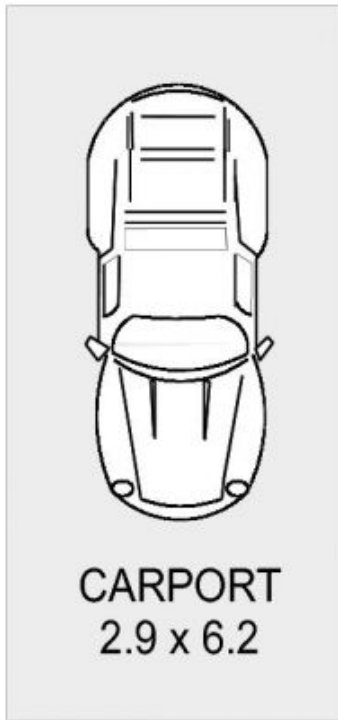

DETACHED

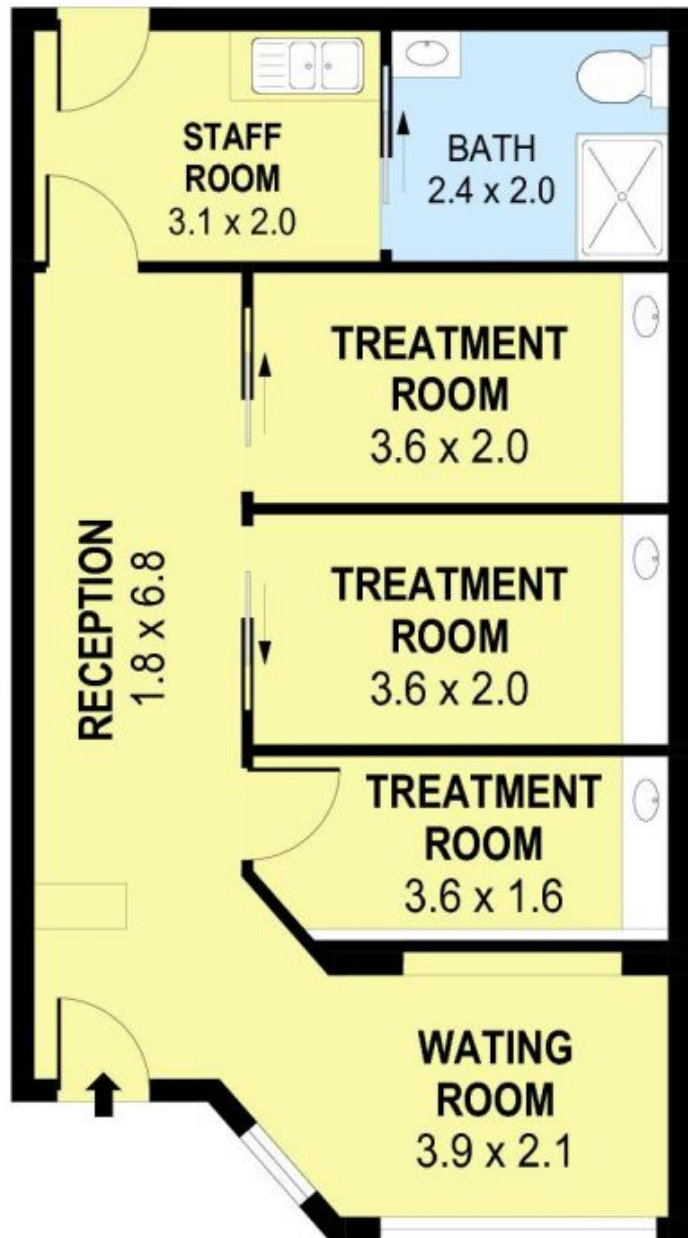

PLANS SHOWN ONLY INDICATIVE OF LAYOUT. DIMENSIONS ARE APPROXIMATE.  
Ref. No: 47831

INT : 54m<sup>2</sup>  
CARPORT : 18m<sup>2</sup>

SHOP 1, 198 GIPPS ROAD

GWYNNEVILLE