



1 Ocean Street Wollongong North NSW

3  2  2 

Presenting a rare opportunity to create the lifestyle you've always dreamed of, only minutes' walk to North Wollongong Beach you cannot miss this spectacular chance. With three bedrooms, two bathrooms and a detached lock up garage make yourself at home and enjoy this great set up with sunroom and fireplace included or alternatively take this chance to create your dream home by renovating or re-designing. Boasting 15.24m of frontage and set on 531 sqm of land, you also have the opportunity to redevelop and build a new home or duplex, subject to council approval.

This Blue Chip location offers everything, from the Beach, to great cafes and restaurants such as Diggies and the Pavilion, the free Gong' shuttle is practically at your doorstep and Wollongong CBD is just up the road.

Land Size : 531 sqm

View : <https://www.jacksonresidential.com.au/6046889>



Mark Jackson
02 4226 3000

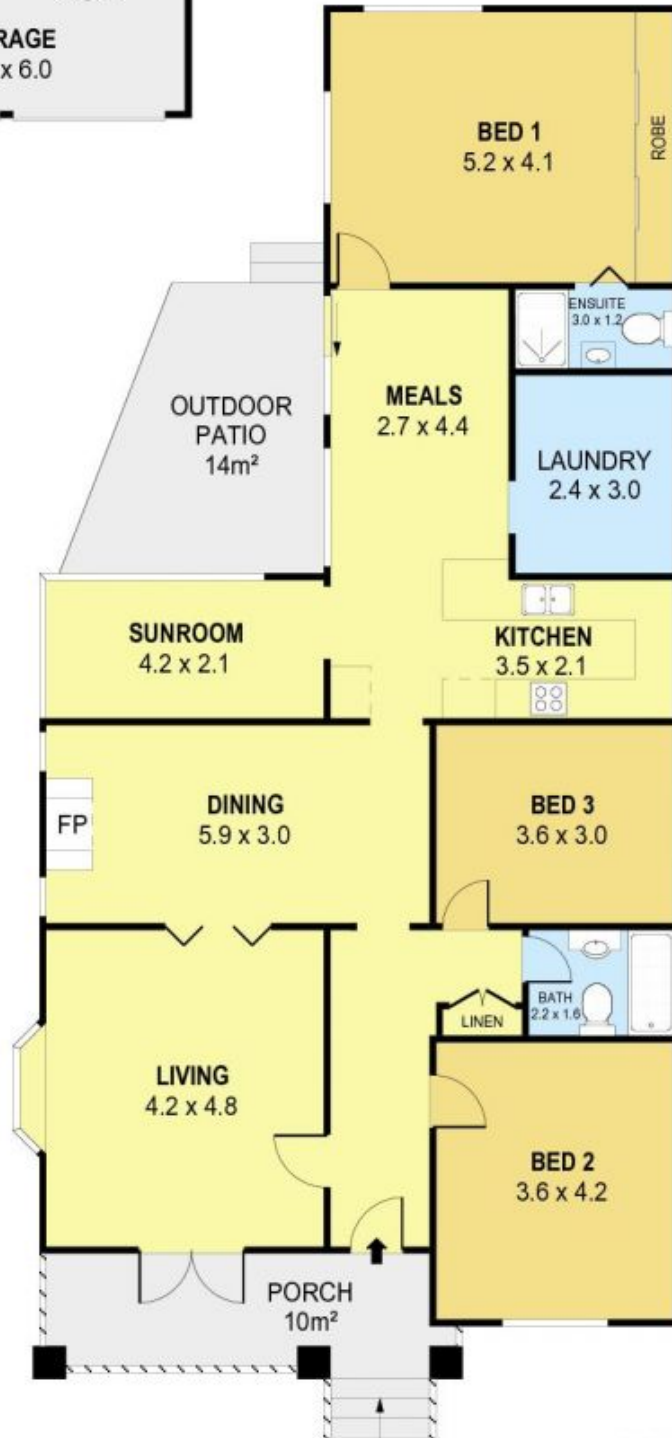
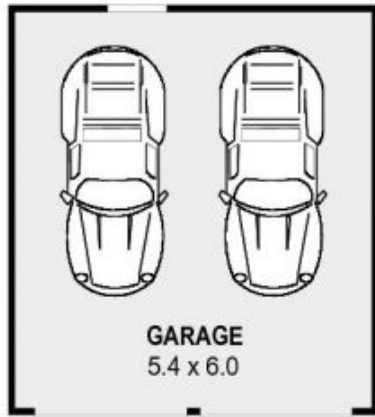

0 1 2 3 4 5 **SCALE (METRES)**

PLANS SHOWN ONLY INDICATIVE OF LAYOUT. DIMENSIONS ARE APPROXIMATE.
Ref. No: 49309

INT : 145m²
EXT : 24m²
GARAGE : 32m²

1 OCEAN STREET

WOLLONGONG