



29 Kiernan Street Gwynneville NSW

2 1 2

Expressions of Interest Close 12 noon 7th August 2019

It's an address in Gwynneville that ticks all the boxes with a north facing home. Full of character with a versatile floor plan offering two bedrooms, one of the living areas can easily be used as a third bedroom. New floor covering throughout living and bedroom areas. Large double garage and a sun drenched backyard. Absolutely everything you need is close by - UOW, Tafe, schools, transport. Ideal property to rent out now and build your dream later.

Highlights:

- * Versatile floor plan
- * Well maintained
- * New floor coverings
- * Ornate cornices, art deco light fittings
- * Gas heating

Price : \$ 820,000
Land Size : 579 sqm
View : <https://www.jacksonresidential.com.au/6047>
145



Mark Jackson
02 4226 3000



MarkDeleted MasonDeleted

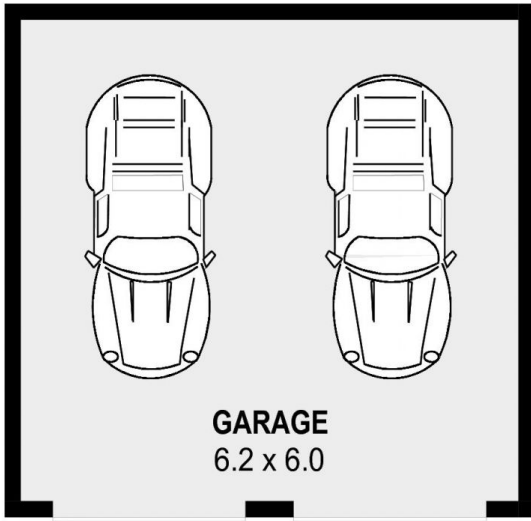

DETACHED

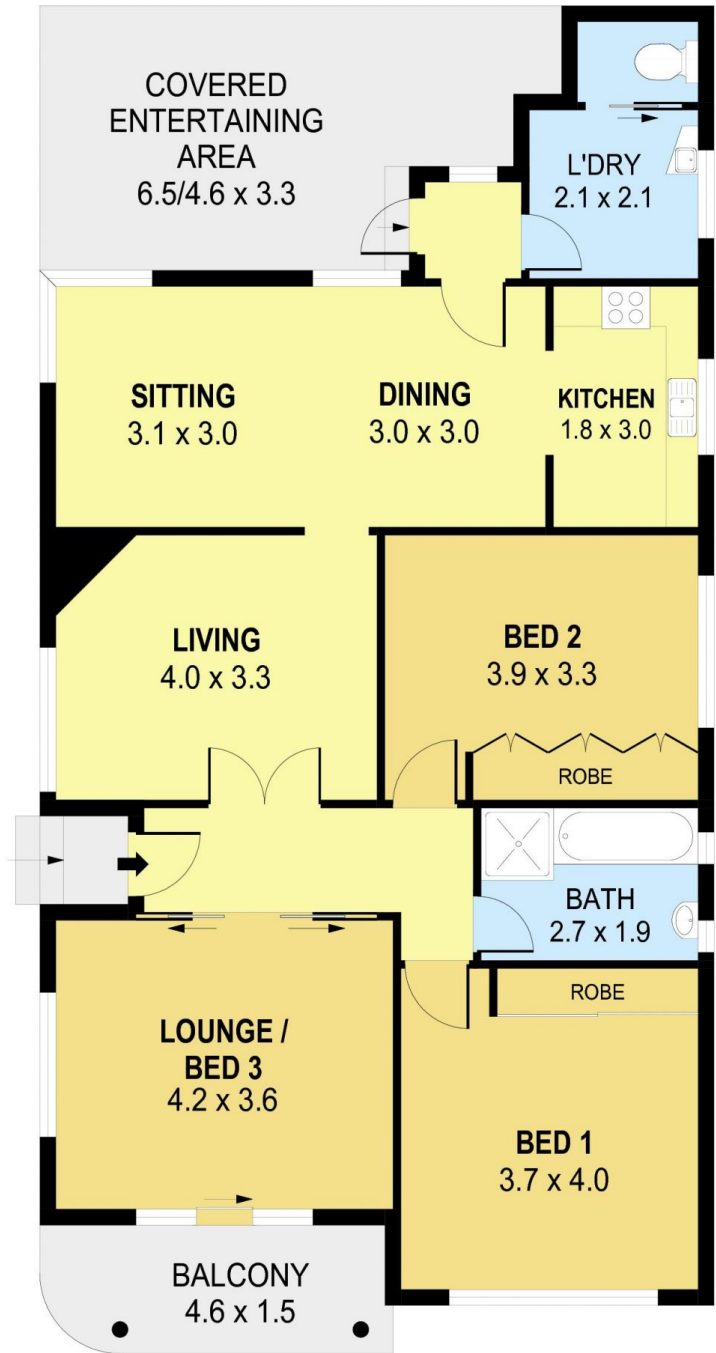

PLANS SHOWN ONLY INDICATIVE OF LAYOUT. DIMENSIONS ARE APPROXIMATE.
Ref. No: 74374

INT : 102m²
EXT : 26m²
GARAGE : 37m²

29 KIERNAN STREET

GWYNNEVILLE