



14 Alkera Crescent West Wollongong NSW

3 1 2

Sitting pretty on the high side of the street this neat light filled cottage has been loved by one family for many years. Lounge/dining has a fire place and reverse cycle air conditioning, there's even a sunroom/rumpus for the kids. Offering a good opportunity to enter the market, update and make it your own.

- * 3 bedrooms
- * L-shaped lounge/dining with r/c air conditioner
- * Sunroom leading to back yard
- * Spacious kitchen
- * 2nd toilet in laundry
- * Garden shed
- * Detached double garage
- * Neat and tidy yard
- * Handy to schools, shops and freeway access.

Price : \$ 550,000
Land Size : 613 sqm
View : <https://www.jacksonresidential.com.au/6047235>



Mark Jackson
02 4226 3000



MarkDeleted MasonDeleted

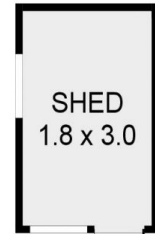
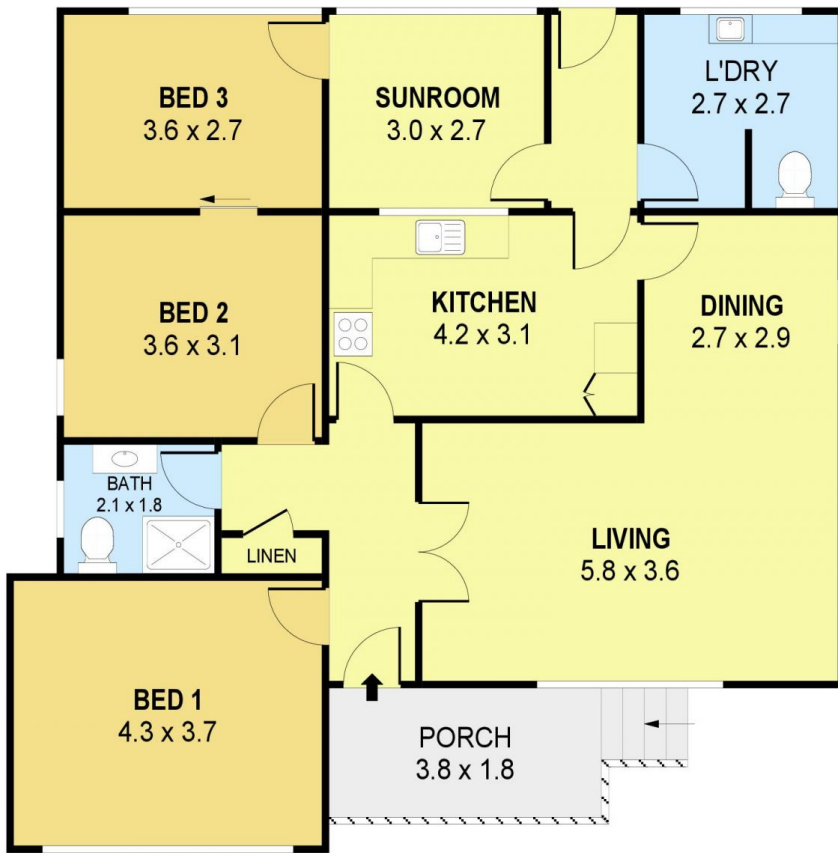

DETACHED

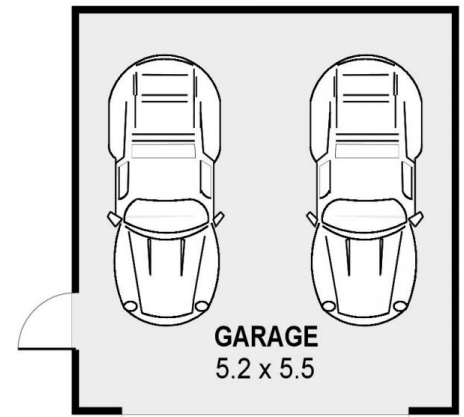

PLANS SHOWN ONLY INDICATIVE OF LAYOUT. DIMENSIONS ARE APPROXIMATE.
Ref. No: 80635

INT : 111m²
 EXT : 7m²
 GARAGE : 29m²
 SHED : 5m²

14 ALKERA CRESCENT

WEST WOLLONGONG