



7 Attunga Street Keiraville NSW

2  1  1 

This delightful 746sqm block is situated in a lovely part of the suburb, offering a wonderful opportunity to be part of this sought after, family friendly area. The 60's cottage is neat and tidy with 2 bedrooms plus a nursery/office off the main. There's a pretty good sunroom out the back and a flat back yard for the kids to play. Close to the village cafes, shops, school and transport. Give her a facelift or design your forever home. Spoilt for choice.

Land Size : 746 sqm

View : <https://www.jacksonresidential.com.au/6047296>

Highlights:

Ideal location in a quiet part of Keiraville

Spacious rooms

Pantry

Nursery/study off main

Some lovely retro features

Walk to the village cafes and shops

Bus around the corner



Mark Jackson
02 4226 3000



Mark Mason
0409 272 430

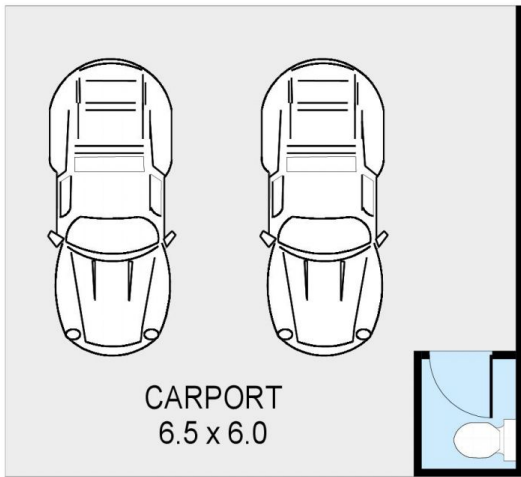

DETACHED

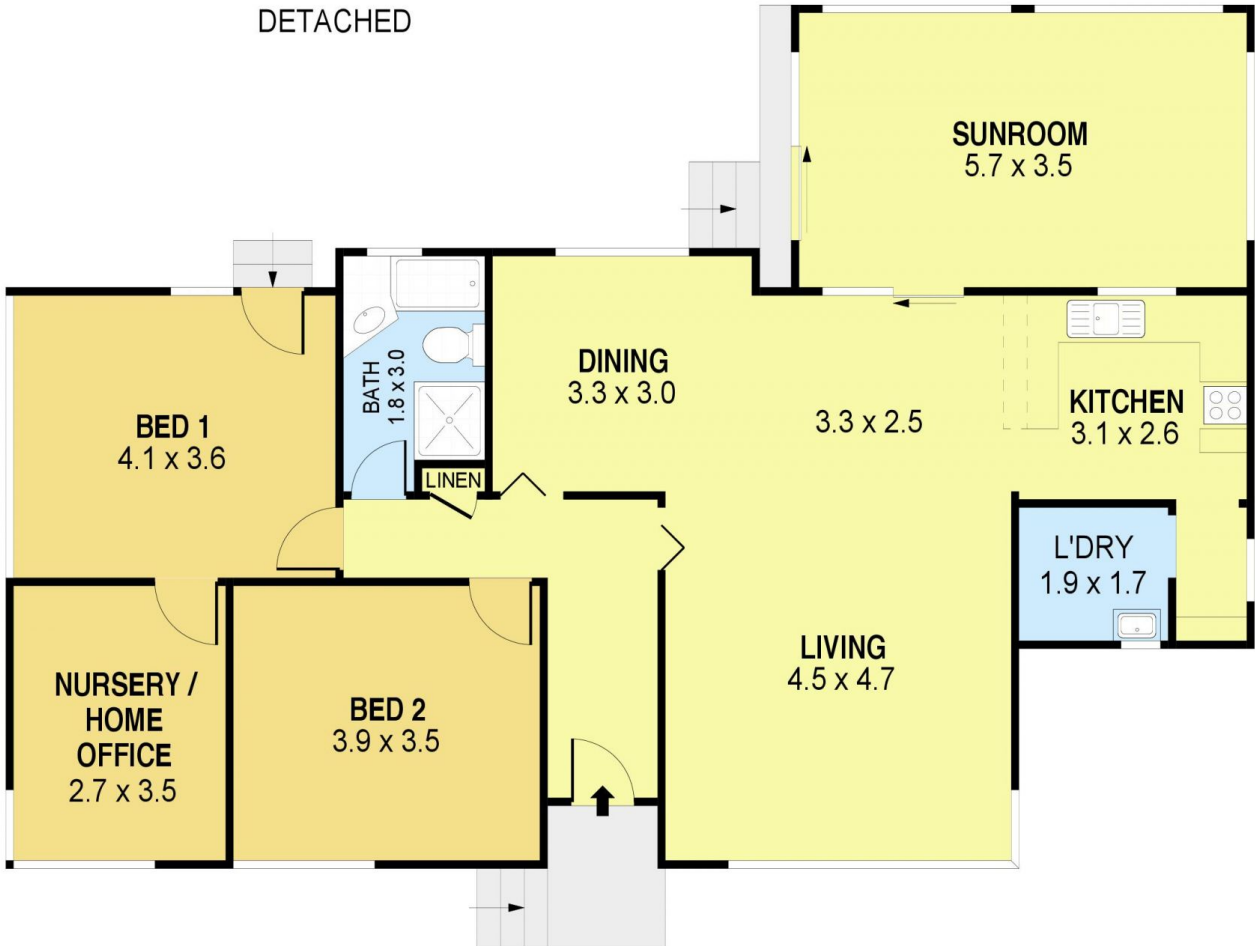

PLANS SHOWN ONLY INDICATIVE OF LAYOUT. DIMENSIONS ARE APPROXIMATE.
Ref. No: 84622

INT	: 126m ²
EXT	: 3m ²
WC	: 2m ²
CARPORT	: 37m ²

7 ATTUNGA STREET

KEIRAVILLE