



7 Attunga Street Keiraville NSW

2  1  1 

Situated in a lovely part of the suburb offering,

- * 2 bedroom with a nurse or study off the main
- * Good sized sunroom
- * Older style kitchen neat & tidy NO DISHWASHER
- * Combined lounge and dining room
- * Flat back yard
- * Carport
- * Walk to village cafes and shops
- * Local transport, schools and university

Land Size : 746 sqm

View : <https://www.jacksonresidential.com.au/6162>
142



Karen White
02 4226 3000



Annette Allen
02 4226 3000

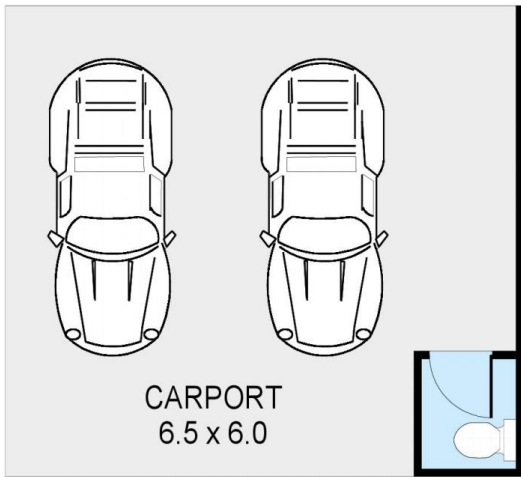

DETACHED

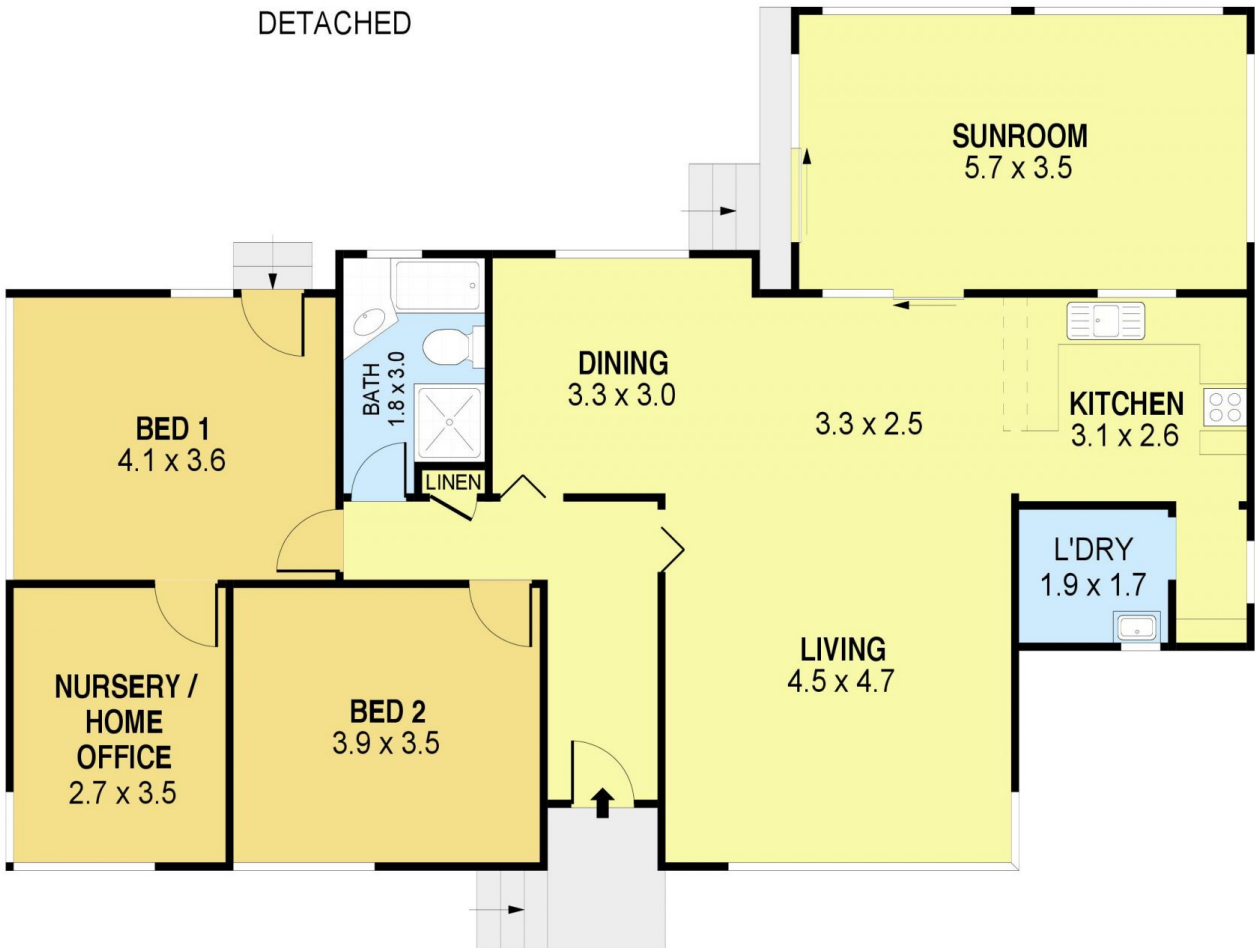

PLANS SHOWN ONLY INDICATIVE OF LAYOUT. DIMENSIONS ARE APPROXIMATE.
Ref. No: 84622

INT	: 126m ²
EXT	: 3m ²
WC	: 2m ²
CARPORT	: 37m ²

7 ATTUNGA STREET

KEIRAVILLE